

inklingo
WELCOME

FREE COLLECTION
Print with Inklingo today!
(\$20 value)



1. GET THE FREE SHAPE COLLECTION

If you do not have the free Inklingo shape collection yet, you can order it, download it, and start printing on fabric in the next few minutes. Go to SHOP > Getting Started

Inklingo is a simpler way to quilt. It is so simple, you can print your first fabric right now. You need a piece of freezer paper, a scrap of fabric, and an iron. That's all.

We suggest you start by printing Inklingo color 11 (page 263) on the wrong side of a scrap of light/medium fabric.

You can learn some nifty tricks for choosing the right ink color (test pages), and making efficient use of fabric (custom page sizes) later.

If you are opening Inklingo for the first time, the [download instructions](#) are under the SUPPORT tab.

2. IRON FREEZER PAPER TO FABRIC

Cut freezer paper 8.5 x 11, iron it to the right side of the fabric, and trim around the freezer paper so the fabric is the same size. (Use a lighter fabric than the red in the photo for your first try.)



Use a hot, dry iron (no steam) and press on both sides—the paper side and the fabric side.

As long as there is a firm bond between the fabric and the freezer paper, jams in the printer are rare. Always wash fabric first to remove the sizing. Otherwise, the freezer paper is not likely to stick well enough.

3. OPEN THE BOOKMARKS

The very first thing you should do *every time* you open an Inklingo shape collection is click the icon on the left side of the Adobe Reader window to open the Bookmarks panel. *Every time!*

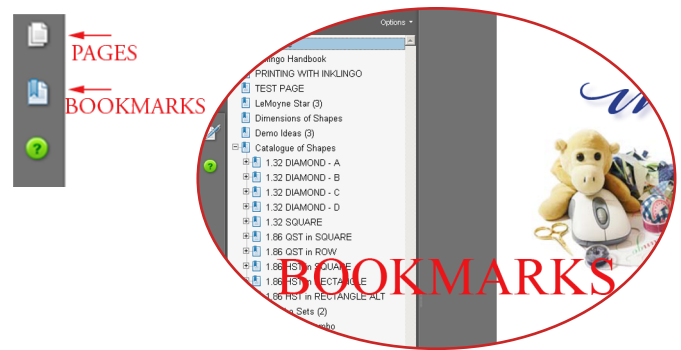

Another way to open the Bookmarks is to go to View > Navigation > Bookmarks. (One of the benefits of Inklingo is that you will learn some simple tips for using your computer.)

You can find your way around by using the Bookmarks, without even knowing the page number! How cool is that?

4. SCROLL DOWN

In the Bookmarks, scroll down to “QST SQU DIA Combo,” the last main heading in the list.

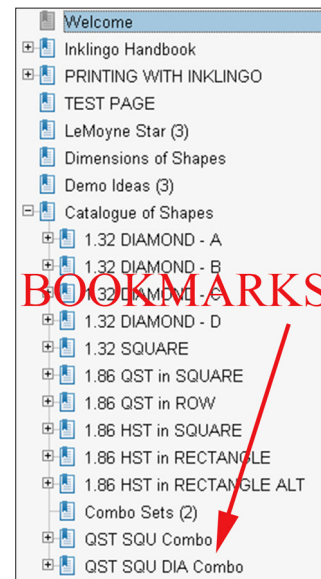

Click on the + sign to the left (a triangle on Mac), to open a list of more pages underneath.

(If you want to skim through Chapter 1 now, it is near the top of the Bookmarks panel, and is called PRINTING WITH INKLINGO. Click to go to other pages and have a look around, if you like. We'll wait.)

5. CLICK ON THE PAGE FOR COLOR 11 7. ADMIRE!

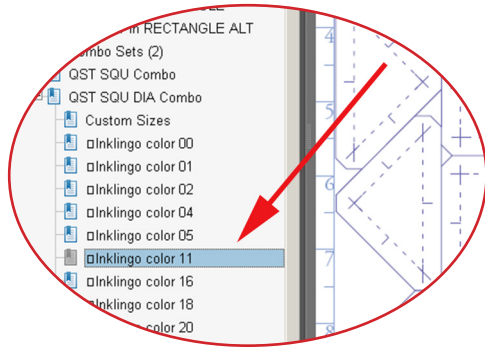

Click on the page for Inklingo color 11 and look at the shapes. You will see triangles (QST), squares (SQU), and diamonds (DIA) drawn with lines in a grayish/purplish color, and the icon to the left of Inklingo color 11 in the Bookmarks will be gray instead of white to indicate that you are on that page.

The description of the shapes is on the page at the main heading “QST SQU DIA Combo,” and the page after that shows suggested custom page sizes. (These two pages are used together.) Below “Custom Sizes” in the Bookmarks there is a list of 20 pages with the shapes in 20 different colors.

Inklingo color 11 should show well enough on most light/medium fabrics, and wash out easily, or at least not show on the front, so we’ll use it first. You want to be on that page for the next step.

6. CLICK TO PRINT

Click File > Print (or Control P, a useful shortcut).

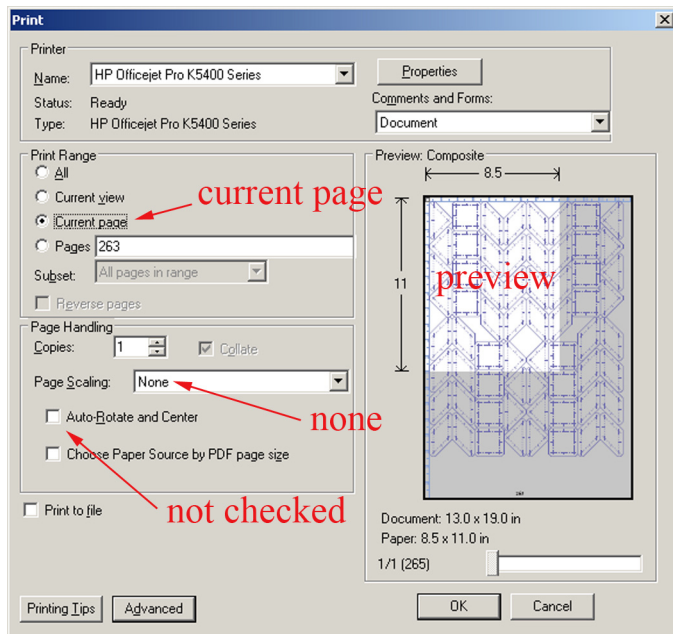

Make sure Page Scaling is set to “none” in the print dialog box (above), so the shapes print the right size.

7. ADMIRE!

The fabric will be printed like the purple fabric here.

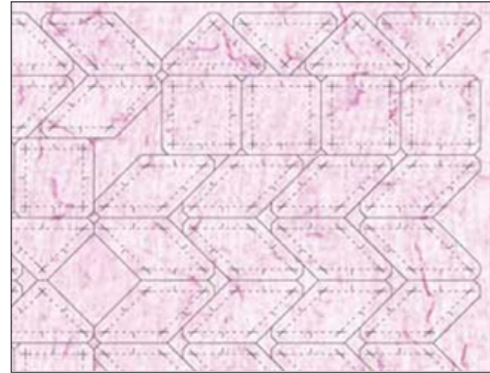

The lines are very fine and perfect, and the advantages are clear: It is easier to cut on a line without any measuring, and it is easier to sew with a line to follow.

When you see precise diamonds, triangles, and squares coming out of your Inkjet printer, we think you will want to print a sheet of a contrasting fabric right away, so you can mix the shapes to sew two mirror image LeMoyne Star blocks for [Tilde’s Tiny Totes](#) (free pattern).

Explore the free shape collection to become familiar with the way the shapes are organized.

If you haven’t already, review Chapter 1 of *The Inklingo Handbook*. It is called PRINTING WITH INKLINGO in the Bookmarks panel of the free shape collection.

8. GO BACK TO THE WEB SITE

Many quilters do not take full advantage of the cool navigation tools in Adobe Reader, but the [Guided Tour](#) explains Bookmarks and more. There is also a two minute video on the [Getting Started](#) page (under the SHOP tab).

Notice that if you had printed fabric 6.75 x 9.75 instead of 8.5 x 11, you would have 8 diamonds, 4 triangles, and 4 squares with no waste—and that is perfect for LeMoyne Star. You can print [Custom Page Sizes](#) with any ordinary Inkjet printer, just by entering the size in the print dialog box. That info is under the SUPPORT tab.

NEXT!

1. Join the [Inklingo Yahoo Group](#).
2. Visit the [Inklingo blogs](#).
3. Find Hidden Treasure under the SUPPORT tab. (Hint: Start with the [Index of Shapes](#).)

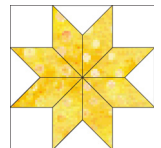

I hope you will join us online. If you have any suggestions or questions, please ask.

LINDA & MONKEY